

EUROPEAN
TELECOMMUNICATION
STANDARD

ETS 300 405

February 1995

Source: ETSI TC-NA

Reference: DE/NA-052104

ICS: 33.080

Key words: MAN, interconnection, ATM

**Network Aspects (NA);
Metropolitan Area Network (MAN)
Interconnection of MAN Switching Systems (MSS)
based on an Asynchronous Transfer Mode (ATM) interface**

ETSI

European Telecommunications Standards Institute

ETSI Secretariat

Postal address: 06921 Sophia Antipolis Cedex - FRANCE

Office address: Route des Lucioles - Sophia Antipolis - Valbonne - FRANCE

Tel.: +33 92 94 42 00 - Fax: +33 93 65 47 16

Copyright Notification: No part may be reproduced except as authorized by written permission. The copyright and the foregoing restriction extend to reproduction in all media.

© European Telecommunications Standards Institute 1995 rights reserved.

Contents

Foreword	5
1 Scope	7
2 Normative references	7
3 Definitions and abbreviations	8
3.1 Definitions	8
3.2 Abbreviations	9
4 Vocabulary.....	9
5 Reference configuration	9
6 CLNI requirements	10
7 Functional architecture	11
7.1 Transit connection related functions	11
7.2 MSS	12
7.3 TAT	12
7.4 ATM-based MSS interconnection management functions	15
8 Protocol reference model for ATM-based MSS interconnection	15
Annex A (informative): Interaction between the AMF and the ATAF blocks	16
Annex B (informative): Bibliography	17
History.....	18

Blank page

Foreword

This European Telecommunication Standard (ETS) has been produced by the Network Aspects (NA) Technical Committee of the European Telecommunications Standards Institute (ETSI).

The purpose of Metropolitan Area Network (MAN) interconnection is to enable users connected to different MANs using the same connectionless bearer service to communicate with each other.

MANs are based upon a shared medium access and cover a restricted geographical area. In order to cover larger areas, MAN Switching System (MSS) interconnection is needed.

MSSs can be interconnected via an Asynchronous Transfer Mode (ATM) based network composed of semi-permanent/permanent Virtual Path Connections (VPCs) and which comprises only ATM crossconnects and possibly Connectionless Servers (CLSs).

This ETS gives the functional definition of the interface between MSS and ATM-based network. The defined interface includes functionalities to support the interconnection of MSS and ATM-based network in the case in which the two networks belong to the same network operator domain and in the case in which they belong to different ones.

Blank page

1 Scope

This European Telecommunication Standard (ETS) describes the interconnection between European standard Metropolitan Area Networks (MANs) by means of an Asynchronous Transfer Mode (ATM) based network. Connectionless service is provided directly or indirectly, according to ITU-T Recommendation I.327 [9]. ATM connections are to be established through ATM crossconnects between the user and Connectionless Servers (CLSs).

Direct interconnection of MANs, based on the Dual Queue Dual Bus (DQDB) protocol is specified in ETS 300 275 [6].

This ETS is restricted to the interconnection of MAN Switching Systems (MSSs) when the MAN users use the Connectionless Broadband Data Service (CBDS) as defined in ETS 300 217 [5]. CBDS may be provided by both types of networks (MAN and ATM-based). The requirements to allow communication between users connected to a MAN and users connected to an ATM-based network, both providing CBDS, is outside the scope of this ETS.

The interconnection of MSSs via ATM connections when MAN users use other services as defined in ETS 300 211 [4] is outside the scope of this ETS.

The defined interface applies to the case in which the MSS and the ATM-based network belong to the same network operator domain and to the case in which they belong to different ones, assuming as basis ETS 300 211 [4] and CCITT Recommendation I.321 [3]. The basic data transfer functionalities at the interface are the same for the two cases. Additional specific management functionalities may be required for each case.

This ETS provides the general principles and functional requirements and specifies the corresponding interface for interconnection of MSSs.

The specification of the interface between MSS and the ATM-based network is based on the Network Node Interface (NNI) and takes into account ITU-T Recommendations I.150 [7], I.361 [10], I.362 [11], I.363 [12], and I.327 [9], ETS 300 275 [6] and ETR 122.

This ETS defines the reference configuration, functional blocks and their corresponding Protocol Reference Models (PRMs) related to MSS interconnection.

2 Normative references

This ETS incorporates by dated and undated reference, provisions from other publications. These normative references are cited at the appropriate places in the text and the publications are listed hereafter. For dated references, subsequent amendments to or revisions of any of these publications apply to this ETS only when incorporated in it by amendment or revision. For undated references the latest edition of the publication referred to applies.

- [1] CCITT Recommendation E.164 (1991): "Numbering plan for the ISDN era".
- [2] CCITT Recommendation I.113 (1993): "Vocabulary of terms for broadband aspects of ISDN".
- [3] CCITT Recommendation I.321 (1991): "B-ISDN protocol reference model and its application".
- [4] ETS 300 211 (1992): "Network Aspects (NA); Metropolitan Area Network (MAN) Principles and architecture".
- [5] ETS 300 217 (1992): "Network Aspects (NA); Connectionless Broadband Data Service (CBDS)".
- [6] ETS 300 275 (1994): "Network Aspects (NA); Metropolitan Area Network (MAN) Interconnection of MANs".

- [7] ITU-T Recommendation I.150 (1993): "B-ISDN asynchronous transfer mode functional characteristics".
- [8] ITU-T Recommendation I.311 (1993): "B-ISDN general network aspects".
- [9] ITU-T Recommendation I.327 (1993): "B-ISDN functional architecture".
- [10] ITU-T Recommendation I.361 (1993): "B-ISDN ATM layer specification".
- [11] ITU-T Recommendation I.362 (1993): "B-ISDN ATM adaptation layer (AAL) functional description".
- [12] ITU-T Recommendation I.363 (1993): "B-ISDN ATM adaptation layer specification".
- [13] ITU-T Recommendation I.432 (1993): "B-ISDN user network interface - Physical layer specification".

3 Definitions and abbreviations

3.1 Definitions

For the purposes of this ETS, the following definitions apply:

ATM crossconnect: This can be either VP cross-connect or VC cross-connect (see ITU-T Recommendation I.311 [8]).

ATM Mapping Functions (AMF) block: The AMF block contains the mapping functionality.

ATM Transit Access Functions (ATAF) block: The ATAF block contains functions to receive and transmit information over a medium. It is based on ATM.

ATM-based MSS Interconnection Management Functions (AMIMF) functional component: This includes the management functions relevant to the handling of the **Connectionless Network Interface (CLNI)**.

Connectionless Network Interface Protocol (CLNIP): See ETR 122.

Connectionless Server (CLS): See ETR 122.

MAN Switching System (MSS): See ETS 300 211 [4].

Connectionless Network Interface (CLNI): An ATM-based interface for the interconnection of MSS and ATM-based networks belonging to the same or to different network operator domains.

MSS Management Functions (MMF) block: See ETS 300 275 [6].

reference point Ym: See ETS 300 211 [4] (note).

NOTE: The reference point Ym is not defined in CCITT or ITU-T Recommendations.

Transit Access Termination (TAT): See ETS 300 211 [4].

Transit Connection Related Function (TCRF): See ETS 300 211 [4] and ITU-T Recommendation I.327 [9].

3.2 Abbreviations

For the purposes of this ETS, the following abbreviations apply:

AAL 3/4	ATM Adaptation Layer type 3/4
AF	Access Facility
AM	Address look-up Module
AMF	ATM Mapping Functions
AMIMF	ATM-based MSS Interconnection Management Functions
ATAF	ATM Transit Access Function
CEQ	Customer Equipment
CLNI	Connectionless Network Interface
CLNIP	Connectionless Network Interface Protocol
CLS	Connectionless Server
CLSF	Connectionless Service Functions
FRM	Forwarding/Receiving Module
IMPDU	Initial Media access control PDU
MAN	Metropolitan Area Networks
MMF	MSS Management Functions
MSS	MAN Switching System
NNI	Network Node Interface
OAM	Operations And Maintenance
PDU	Protocol Data Unit
PI	Protocol Identifier
PRM	Protocol Reference Model
PTO	Public Telecommunication Operator
RM	Routeing Module
QoS	Quality of Service
TAT	Transit Access Termination
TCRF	Transit Connection Related Function
TL	Transmission Link
UMI	User-MAN Interface
VPC	Virtual Path Connection

4 Vocabulary

For B-ISDN related terms and definitions, see CCITT Recommendation I.113 [2].

5 Reference configuration

The reference configuration for the interconnection of MSSs via an ATM-based network is depicted in Figure 1.

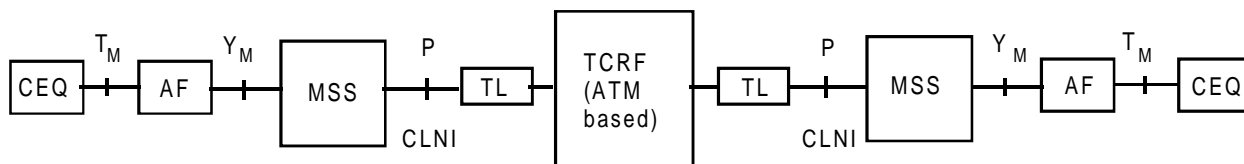

CEQ: Customer Equipment
 AF: Access Facility
 TL: Transmission Link

Figure 1: Reference configuration for MSS interconnection

The CLNI is located at the P reference point.

The CLNI is defined for the two cases of interconnection identified in clause 6.

6 CLNI requirements

The characteristics of the interface CLNI between MSS and the ATM-based network support the service provided at the User-MAN Interface (UMI), described in ETS 300 217 [5].

The interconnection of MSSs via an ATM-based network allows the transparent transfer of connectionless data units between P reference points of different MSSs connected to the ATM-based network. The connectionless data unit sequence integrity is preserved between MSSs to maintain the sequence order between end users.

The routing of connectionless data units is based on the hierarchical CCITT Recommendation E.164 [1] number. Both individual and group addressed data units transport handling is provided at the interface.

The defined interface (CLNI) is applicable in two cases: the MSS and the ATM-based network belong to the same network operator, or they belong to different Public Telecommunication Operators (PTOs). In the first case additional functions for internal routing and congestion management may be supported; in the second one operational functions related to the interconnection of networks managed by different PTOs may be provided.

Two techniques are allowed to forward/receive the data units across the CLNI interface: encapsulation of the IMPDUs defined at the Ym reference points within the CLNIP PDUs or non-encapsulation of the IMPDUs within the CLNIP PDUs (see ETR 122). The following requirements apply:

- a Protocol Identifier (PI) value, carried in the CLNIP-Protocol Data Unit (CLNIP-PDU) header, indicates whether or not an access IMPDU is encapsulated;
- for NNI applications between network operators, encapsulation shall be used for both group and individually addressed PDUs. The encapsulation mechanism is described in ETR 122;
- for NNI applications within a single operator's network, encapsulation and/or non-encapsulation may be used by the network operator;

NOTE: It is recommended to use only one technique within one PTO domain.

- every network node (CLS or MSS) shall be able to decapsulate an encapsulated data unit and to forward a non-encapsulated data unit;
- the decision whether decapsulation is required shall be based on the PI value;
- there is no difference between a CLS and a MSS as far as encapsulation and non encapsulation of IMPDU is concerned.

The interface between an MSS and the ATM-based network is based on the NNI.

7 Functional architecture

7.1 Transit connection related functions

The TCRF functional group covers the functions, such as address handling and routing, of the transit network as defined in ETS 300 211 [4].

The TCRF is ATM-based and includes the ATM switched capabilities and possibly the Connectionless Service Functions (CLSF).

The ATM switched capabilities support the ATM transport network functionalities, corresponding to the Physical and ATM layers of the B-ISDN PRM, as defined in ITU-T Recommendation I.311 [8].

For interconnection of MSSs, these functionalities are provided by the ATM cross-connect network element, which supports the Virtual Path Connections (VPCs) defined between two MSSs or between a MSS and the network element providing CLSF, and is directed by management plane functions.

The CLSF terminates the B-ISDN connectionless protocol, providing functions such as address handling/resolution and routing of connectionless data units, and includes functions for the adaptation of the connectionless protocol to the intrinsically connection oriented ATM transport network functionalities. The CLSF are provided by the connectionless server.

In Figure 2 is shown an example of TCRF implementation including ATM crossconnects and a connectionless server.

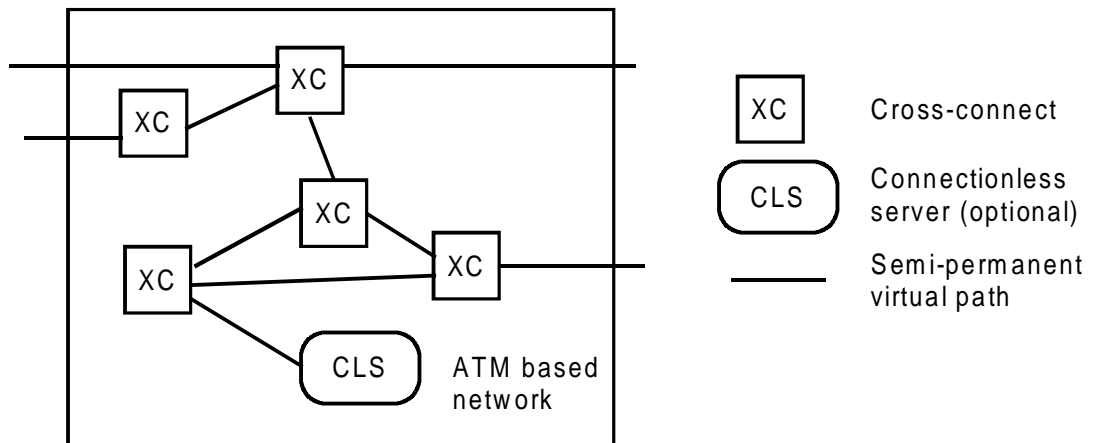

Figure 2: Example of TCRF implementation

7.2 MSS

In order to provide the functionality for the interconnection of MSS via ATM connections, the following functional blocks are envisaged inside the MSS (see Figure 3):

- the MMF block, which provides the functions related to the MSS management. As far as the management of the CLNI is concerned the AMIMF functional component is envisaged;
- the TAT block, which includes the functions for terminating the transit link at the P reference point.

A MSS can contain more than one TAT, one for each physical layer connection. The appropriate TAT for each connectionless data unit to be forwarded on the ATM-based network is chosen by the MSS on the basis of the addressing information.

For each physical layer connection more than one VPC can exist (see ITU-T Recommendations I.311 [8] and I.432 [13]).

NOTE: The complete functional description of MSS is given in ETS 300 211 [4]; only the functions related to MSS interconnection via ATM are listed in this ETS.

7.3 TAT

The functions described in this subclause do not imply any particular implementation.

As shown in Figure 3, the TAT terminates the transit link at the P reference point where the CLNI is defined.

Two functional blocks, namely ATAF and AMF, are envisaged within the TAT (see Figure 3):

- **ATAF block:** this contains functions to receive and transmit information over a medium. It is based on ATM and includes the protocol functionalities of the Physical, ATM, ATM Adaptation Layer type 3/4 (AAL type 3/4) and CLNIP layers of the B-ISDN PRM;
- **AMF block:** this contains the mapping functionalities.

The interaction between the ATAF and AMF is described in annex A, in terms of information exchanged between the two blocks.

A detailed functional description of the two blocks follows (the functions described do not imply any particular implementation):

- ATAF:** in the direction from the MSS to the CLNI, this block provides the formatting of the CLNIP-PDU using the information received from the AMF block: the control information is used to construct the CLNIP-PDU header and the Data is inserted in the payload. The CLNIP-PDU is then forwarded to the Routing Module (RM).

In the opposite direction the CLNIP-PDU is received from the CLNI and the extracted payload and control information is passed to the AMF block.

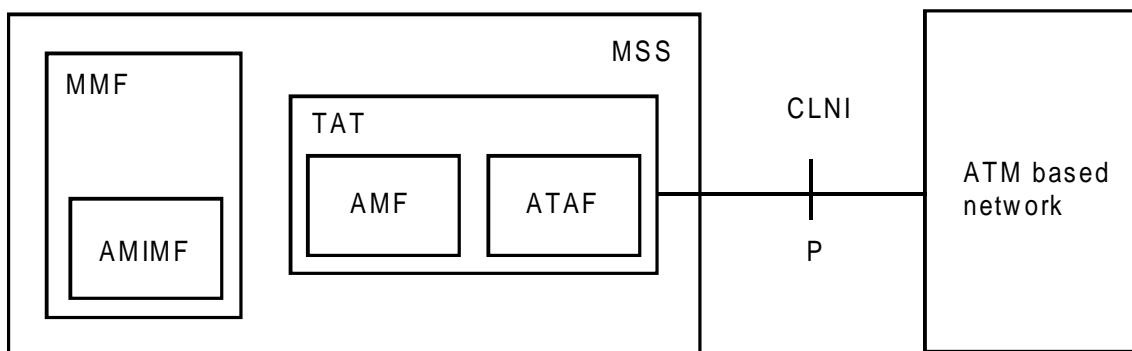

Figure 3: MSS functional model

b) **AMF**: three main modules are identified within this block:

1) Address look-up Module (AM):

- **from the MSS to the CLNI.**

The module receives the IMPDU. It examines the PI value.

If the PI value indicates that encapsulation has already occurred, it performs group address resolution functions if needed and if the MSS has the responsibility for the particular group; the PI value is set to indicate encapsulation.

If the PI value indicates that encapsulation has already occurred, and group address resolution has already been performed, then it treats the Initial Media access control PDU (IMPDU) as an individual addressed IMPDU, but with the PI value set to indicate encapsulation.

If the PI value does not indicate encapsulation, it performs group address resolution functions if needed and if the MSS has the responsibility for the particular group. On the basis of:

- the interface type (intra or inter domain);
- the use of the encapsulation procedures or not within the network domain; and
- the management information,

it sets the PI value.

The IMPDU and the information obtained from the group address resolution functions is then forwarded to the Routing Module (RM);

- **from the CLNI to the MSS.**

The module receives the IMPDU from the Forwarding/Receiving Module (FRM). It decides, on the basis of the destination address, if it has to discard it (e.g. unknown address). If not, it performs, when needed, group address resolution functions; the IMPDU is then passed to the MSS internally.

2) RM:

The RM receives the IMPDU and the information obtained from the group address resolution functions from the AM. It determines the appropriate VPC(s) on the basis of the destination address(es), then it passes the IMPDU and the information obtained from the group address resolution functions to the FRM together with the selected VPC(s).

3) FRM:

- **from the MSS to the CLNI (forwarding).**

The FRM receives the IMPDU, the information obtained from the group address resolution functions and the selected VPC(s) from the RM.

It performs the following operations for each CLNIP-PDU to be sent across the CLNI:

- it determines the control information (e.g. it sets the PI value according to the encapsulation/non encapsulation parameter);
- on the basis of the encapsulation/non encapsulation parameter it constructs the Data:
 - if the parameter indicates the use of encapsulation, it constructs the Data according to ETR 122, unless the parameter indicates the use of encapsulation prior to the IMPDU arriving at the TAT, in which case it constructs the Data from the encapsulating IMPDU payload;
 - if the parameter indicates the use of non-encapsulation, it constructs the Data by extracting the IMPDU payload.

Then it sends the control information and the Data to the ATAF block for the transmission on the identified VPC.

- **from the CLNI to the MSS (receiving)**

The FRM receives the Data and the control information from the ATAF block.

It handles the Data on the basis of the PI value:

- if the PI indicates the use of encapsulation, it constructs the IMPDU from the Data according to ETR 122; it performs integrity checks on it. If valid, the IMPDU and the other relevant information (e.g. addressing) are passed to the AM, otherwise the IMPDU is discarded;
- if the PI indicates the use of non-encapsulation, it constructs the IMPDU using the control information and the Data received from the ATAF block; then it passes the IMPDU and the other relevant information (e.g. addressing) to the AM.

The information flow among these modules is depicted in figure 4.

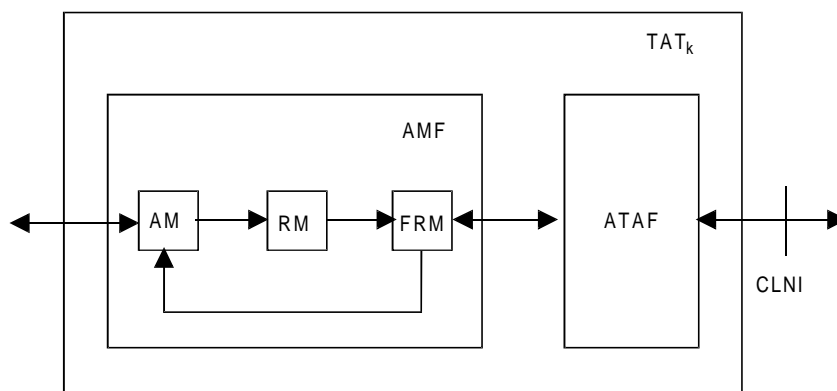

Figure 4: Information flows within the TAT block

7.4 ATM-based MSS interconnection management functions

The AMIMF is included inside the MMF block and is depicted in Figure 3.

The AMIMF includes both protocol layer management functions for the ATAF block and management functions related to operational aspects of the AMF block (e.g. loading and error reporting in case of unknown address).

The AMIMF also contains functionality to gather statistics for traffic exchanged between MSSs and the ATM-based network.

The AMIMF supports internal routing and congestion management functions for the interconnection within the same network operator domain, and provides operational functions (e.g. provision of charging capabilities) for the interconnection between different network operator domains.

The AMIMF also includes virtual path management functions for the management of VPCs in accordance with the B-ISDN PRM Management plane protocol stack as given in CCITT Recommendation I.321 [3].

8 Protocol reference model for ATM-based MSS interconnection

According to CCITT Recommendation I.321 [3] the B-ISDN PRM for ATM is composed of a user plane, a control plane and a management plane.

For the purpose of this ETS only the user and management plane functions are taken into account.

The PRM for the CLNI is shown in Figure 5.

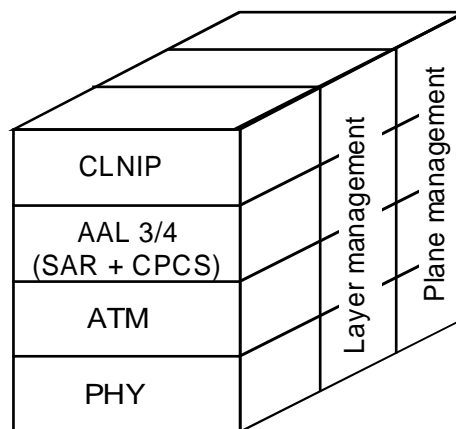

Figure 5: PRM for CLNI

For the user plane the physical, ATM, AAL 3/4 and CLNIP layers are identified. The CLNIP protocol is defined in ETR 122. The functionalities and characteristics of each layer are given in CCITT Recommendation I.321 [3], and ITU-T Recommendations I.150 [7], I.361 [10], I.362 [11], I.363 [12] and I.327 [9].

The management plane includes functionalities of local co-ordination, that reside in the plane management, functionalities related to the Operations And Maintenance (OAM) for each corresponding layer of the user plane and functionalities for the management of permanent/semi-permanent VPCs, that reside in the layer management.

Annex A (informative): Interaction between the AMF and the ATAF blocks

This annex illustrates the interaction between the AMF and the ATAF block, inside an MSS.

Information flow

At the transmitting side, the AMF block receives the IMPDU from the internal part of the MSS and passes a set of parameters to the ATAF block; on the basis of these parameters, a corresponding CLNIP-PDU is constructed and forwarded by the ATAF block to the CLNI.

At the receiving side, the ATAF block receives a CLNIP-PDU from the CLNI and passes a set of parameters to the AMF block; on the basis of these parameters, a corresponding IMPDU is obtained by the AMF block and passed internally to the MSS.

The set of parameter exchanged between the AMF and the ATAF blocks is the same in both directions, from the AMF to the ATAF and vice versa.

The parameter are: control information (Source_Address, Destination_Address, PI, Quality of Service (QoS), Header_Extension); and Data.

At the transmission side (AMF to ATAF) the parameters assume the following semantics:

- **Source_Address:** this parameter identifies the source interface that originated the IMPDU;
- **Destination_Address:** this parameter contains the address of the intended recipient(s); the address may be either an individual or a group address;
- **PI:** this parameter indicates if the encapsulation or non-encapsulation technique is to be used in the construction of the CLNIP-PDU;
- **QOS:** this parameter specifies the QoS desired for the transfer of the resulting CLNIP-PDU;
- **Header_Extension:** this parameter indicates the contents of the Header Extension field of the resulting CLNIP-PDU;
- **Data:** this parameter is constructed according to ETR 122 or contains the payload of the IMPDU, depending on the PI value.

These parameters are used by the ATAF block to encode the CLNIP-PDU. For the format and the encoding of the CLNIP-PDU, refer to ETR 122.

At the receiving side (ATAF to AMF) the parameters assume the following semantics:

- **Source_Address:** this parameter contains the value of the Source Address field of the received CLNIP-PDU;
- **Destination_Address:** this parameter contains the value of the Destination Address field of the received CLNIP-PDU;
- **PI:** this parameter indicates if the encapsulation or non-encapsulation technique has been used in the construction of the received CLNIP-PDU;
- **QOS:** this parameter contains the value of the QoS field of the received CLNIP-PDU;
- **Header_Extension:** this parameter contains the value of the Header Extension field of the received CLNIP-PDU;
- **Data:** this parameter contains the payload of the CLNIP-PDU.

These parameters are used by the AMF block to obtain the original IMPDU.

Annex B (informative): Bibliography

- 1) ETR 122 (1994): "Network Aspects (NA); Connectionless Broadband Data Service (CBDS) over Asynchronous Transfer Mode (ATM)".
- 2) ITU-T Recommendation I.364: "Support of broadband connectionless data service on B-ISDN".

History

Document history	
February 1995	First Edition
December 1995	Converted into Acrobat Portable Document Format (PDF)